

# Guidelines for safe kerbline protection

*RTS 8*

## Disclaimer

While this document is believed to be correct at the time of publication, the Land Transport Safety Authority, Transit New Zealand and their employees or agents involved in preparation and publication cannot accept any liability for its contents or for any consequences arising from its use. People using the contents of the document should apply, and rely on, their own skill and judgement. They should not rely on its contents in isolation from other sources of advice and information.

November 1993

Reprinted June 1998, September 2001

Land Transport Safety Authority

PO Box 2840

Wellington

Telephone 04 494 8600

Fascimile 04 494 8601

Transit New Zealand

PO Box 5084

Wellington

Telephone 04 499 6600

Facsimile 04 496 6666

ISSN: 1170-5337

ISBN: 0-478-08610-5

## Preface

The Land Transport Safety Authority has a vision to promote the social and economic prosperity of New Zealanders by making all aspects of land transport as safe and efficient as our country can afford. In order to transform our vision into reality, the Land Transport Safety Authority is developing policies, standards and guidelines that encourage land transport participants to accept their responsibilities for safety, while allowing them maximum flexibility.

This guideline has been developed at the request of road controlling authorities to assist them in their selection of appropriate and safe methods of kerbline protection. It highlights some existing practices which are of concern to the Land Transport Safety Authority and also promotes the use of a new innovation in roadside furniture in New Zealand, the plastic bollard.

It is my hope that all road controlling authorities will adopt this guideline and that the practical information it provides will enhance the safety of the New Zealand roading network for all road users.

Alan Wilcox  
Director, Land Transport Safety.

## Contents

Preface	3
1. Introduction	5
2. Summary	6
3. Existing practices	7
4. Guidelines	8
4.1 Types of kerbline protection	8
4.2 Recommended plastic bollard	11
5. Legal aspects	13
6. References	14
7. Acknowledgements	15
Appendix 1	16
Appendix 2	17

## 1. Introduction

The increasing use of concrete bollards, rocks, posts and other unforgiving items of roadside furniture to prevent vehicle encroachment onto berms and footpaths, has become a matter of concern to the Land Transport Safety Authority in recent years.

The often fatal consequences of road users colliding with these objects and the lack of appreciation of their dangers by some road controlling authorities has prompted the development of these guidelines. A Working Group comprising representatives from the Land Transport Safety Authority, Transit New Zealand and local authorities was convened to assist in the preparation of this document.

As the current use of concrete bollards and rocks, as devices for kerblines protection, is limited to a small number of sites, there is limited reported injury accident data available for carrying out risk reduction analysis. A previous case study [1] has illustrated that ornamental rocks placed on traffic islands can compromise the basic traffic engineering principle of leaving the roadside free from solid objects and subsequently increase the risk of serious or fatal injury to road users colliding with these objects.

The aim of these guidelines is to focus the attention of the traffic engineering profession on the need to improve some of the existing practices in the area of kerblines protection. Also to recommend a number of preferred options and outline situations in which these options could be used.

## 2. Summary

Concrete bollards, rocks and large diameter timber posts are not recommended as devices for kerbline protection. The use of these guidelines will assist road controlling authorities in selecting the most appropriate method of kerbline protection from a number of preferred alternatives, these include:

- road widening and the provision of auxiliary turn lanes
- plastic bollards
- safety barriers
- landscaping and planting
- barrier kerbing.

Road controlling authorities should be aware of their social responsibility to provide the safest possible roading environment and consider the safety of all road users when selecting and installing kerbline protection.

### 3. Existing practices

During the preparation of this document it became clear that there was no uniform rationale behind the use of kerblines in New Zealand. Similarly there was little or no uniformity in the methods or devices used to achieve this protection.

The need for kerblines arises as a result of a variety of actual and perceived problems, these include:

- motorists travelling wholly or partially on berms and footpaths to avoid delays caused by queuing at intersections
- motorists travelling over traffic islands to access right turn bays when queuing traffic obstructs this access
- motorists travelling on the roadside to by-pass intersections or avoid turning restrictions
- motorists parking on grassed berms, footpaths or other roadside areas at inappropriate locations
- vehicle intrusion into pedestrian areas such as malls
- collision with shop facades
- accidental or deliberate encroachment onto kerblines that may form kerb-extensions or threshold islands, particularly in areas of Local Area Traffic Management or other low speed environments
- deliberate encroachment onto grassed berms to cause wilful damage.

These problems may result in:

- damage to footpaths, grassed berms, plantings, service ducts and underground services
- damage to buildings and other private property
- risk of injury to pedestrians and other vulnerable road users.

Concrete bollards, ornamental rocks and large diameter timber posts have become increasingly popular devices for use as kerblines. While there is little doubt that these devices effectively deter vehicle encroachment onto grassed berms, it is also clear that collision with these devices can inflict serious or fatal injury. To date this has occurred at a number of locations throughout New Zealand.

The existing use of these and similar devices by some road controlling authorities implies that these authorities consider them to be suitable traffic control devices. However in selecting these devices there has been a lack of appreciation of the need to consider their frangibility, reflectivity and uniformity, characteristics that are instinctively considered by the traffic engineering profession when choosing other traffic control devices.

## 4. Guidelines

### 4.1 Types of kerbline protection

A wide range of alternatives exist for kerbline protection. In assessing the need for such protection it is important for the road controlling authority to determine at an early stage whether it is addressing a demonstrable problem and whether its scope requires some form of engineering improvement. In some situations damage to berms and footpaths can be traced to a limited number of local motorists who could be identified, contacted and educated in correct driving behaviour.

Vehicle encroachment and subsequent damage to berms and footpaths near an intersection can sometimes be the first indication to the road controlling authority that the intersection may be exceeding its capacity and causing excessive delay during peak times.

Once the extent of the problem has been determined it may be necessary to select a suitable form of improvement. This may range from road widening to the installation of an acceptable form of kerbline protection.

Table 1 in Appendix 1 recommends a number of preferred methods of kerbline protection and outlines situations in which they could be used. The remainder of this section provides additional information on the types of kerbline protection recommended in Table 1.

#### 4.1.1 Road widening

Damage to berms and footpaths near an intersection can sometimes be the first indication to the road controlling authority that the intersection may be exceeding its capacity and causing excessive delay during peak times. Depending on site and cost considerations, road widening may be an appropriate treatment.

At sites where the need for kerbline protection is found to be as a direct result of excessive delay at an adjacent intersection, the appropriateness of the control and the capacity constraints of that intersection should be reviewed. Desirable options to be considered at the first stage of the review should include:

- a change in intersection control
- improvements/modifications to the existing control
- road widening on the approach to improve capacity and vehicle stacking
- provision of auxiliary turn lanes.

At sites where widening is desirable but is precluded in the short-term by cost considerations, it may be necessary to install an interim method of kerbline protection, with road widening programmed for completion as soon as possible.

#### 4.1.2 Plastic bollards

A wide range of plastic (E.BA plastic – a rubberised, impact resistant, UV stabilised compound) bollards are currently available overseas. These have been developed for a variety of uses including:

- delineation of kerblines and traffic islands
- delineation and enhancement of Local Area Traffic Management techniques
- kerbline protection.

Suitably designed and located plastic bollards provide a relatively low cost, high visibility, frangible and flexible method of kerbline protection. While appearing to be a formidable barrier and therefore providing a high level of protection to berms and footpaths, the devices can be installed at most sites with a minimum of disruption to traffic and for a minimal capital cost.

It is logical to assume that the use of the plastic bollard as an alternative to rocks and concrete bollards, reduces the risk of serious or fatal injury to vulnerable road users involved in collision with the device.

Plastic bollards can be used at sites where there is sufficient width for them to be accommodated within the berm or on the footpath such that their presence does not impede the passage of pedestrians, become a hazard for disabled pedestrians, or compromise the visibility of pedestrians, particularly children.

The use of plastic bollards can be particularly appropriate at sites with a high pedestrian concentration, where a safety barrier (refer 4.1.3) or a barrier kerb (refer 4.1.5) could become an unnecessary impediment to pedestrian movement. It should be noted that as plastic bollards are frangible, they provide only partial pedestrian protection.

Plastic bollards may also be used on traffic islands to support RG 17 and RG 17.1 (Keep Left) signs (refer 4.2.2).

Section 4.2 of this guideline deals with the design and installation of a range of plastic bollards primarily for kerbline protection. It is anticipated that ongoing trials of this design will highlight its usefulness for other applications.

### **4.1.3 Safety barriers**

At sites where kerbline protection is required because of deliberate encroachment onto the roadside and where there is a history of loss of control accidents which have resulted in collision with a particular roadside hazard (or pedestrians), the installation of some form of safety barrier may be appropriate.

For the purposes of this guideline, the term 'safety barrier' refers to W-section guard rails and concrete barriers such as "New Jersey" or "Tric Block" barriers (barriers that have undergone considerable crash test research). The use of other barriers such as metal pedestrian fences is not addressed by this guideline and such barriers should only be used when they have undergone crash test research to quantify and ensure their safety benefits.

Safety barriers are generally used to prevent errant vehicles from colliding with roadside hazards such as embankments or buildings close to the road boundary. They have become commonly used on medians as a means of separating opposing traffic and are occasionally used for pedestrian protection, property protection and at road work sites.

In addition to their protection of roadside hazards, effective safety barriers assist drivers in regaining control of errant vehicles with a minimum of deflection back onto the roadway.

The continuous nature of a safety barrier may limit its use in areas where there is a high concentration of pedestrians or frequent driveways. At some sites it may be impractical or unnecessary to force pedestrians to use crossing points at the end of the barrier. The ends of safety

barriers can themselves create a hazard, therefore they are not recommended for use in situations where it may be necessary to have gaps in the barrier. Safety barriers should always be of sufficient length to incorporate correct end treatments.

Safety barriers can be used at sites where there is sufficient width for them to be accommodated within the berm, such that there is adequate clearance between the barrier and the hazard being shielded (or pedestrian being protected). Structural adequacy crash tests [2] indicate that this clearance should be at least 1 metre.

For further details on safety barrier selection and installation refer to *Safety Barriers* [3].

#### 4.1.4 Landscaping and planting

Landscaping and planting as a method of kerblines protection requires careful selection of the form of the landscaping and the varieties of plants to be used. This method will generally require a wide berm area between the kerblines and the footpath.

The important principles to be incorporated into the design of landscaping and planting for kerblines protection are:

- all impactable objects used (including trees) should be frangible
- the form of the landscaping should minimise the risk of 'roll-over' for errant vehicles
- future growth of planting should not compromise sight distance requirements near intersections, pedestrian crossings, traffic signals etc.
- visibility of pedestrians, especially children, should not be compromised.

All designs should adhere to the general principles and techniques for roadside planting referred to in *Guidelines for planting for road safety* [4].

For detailed information refer to *Guidelines for planting for road safety* [4] and *RTS 6 Guidelines for visibility at driveways* [5].

#### 4.1.5 Barrier kerbing

Barrier kerbing, also called "non-mountable kerbing", is occasionally used as a means of kerblines protection. Little is known about the safety benefits of non-mountable kerbing and it should, therefore, be used with caution. As barrier kerbing can create difficulties for pedestrians, particularly elderly or disabled pedestrians, it is not recommended for use in areas of high pedestrian concentration.

Barrier kerbing is unlikely to deter deliberate encroachment onto the roadside by heavy motor vehicles, i.e. trucks and buses.

At sites where there is insufficient footpath or berm width to install other forms of kerblines protection, barrier kerbing may be appropriate. It may also be useful at sites where extreme super-elevation reduces the visual impact of a standard kerb profile.

Information collected from both New Zealand and Australia indicates that the maximum height recommended for the front face of any non-mountable kerb is 220 millimetres.

## 4.2 Recommended plastic bollard

The broad specifications detailed below for a standard range of plastic bollards were arrived at as a result of:

- previous experience with kerbline protection by members of the Working Group
- ongoing field trials of various bollard types underway in Manukau City
- the need to standardise a device which is likely to have a multiplicity of uses.

The Land Transport Safety Authority is continuing to trial the recommended plastic bollard to monitor its effectiveness and road safety benefits.

### 4.2.1 Shape and size

The following photograph illustrates the recommended plastic bollards. The range is made up of three sizes (Types A, B and C) which can be configured in a number of ways depending on site and user requirements. Please refer to Figure 1 in Appendix 2 for the recommended dimensions of these devices.

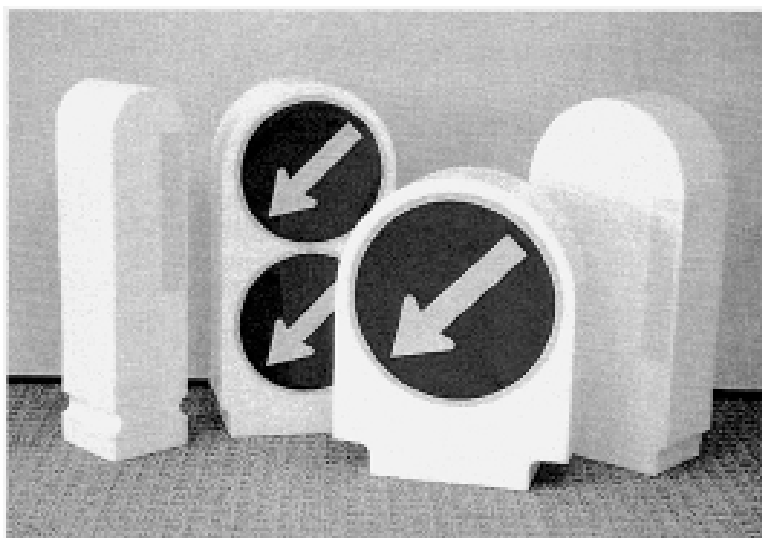

## 4.2.2 Colour

Plastic bollards used as supports for RG 17 and RG 17.1 (Keep Left) signs, generally used on traffic islands, must be white in colour (6). Plastic bollards used for kerblines protection and non-sign supporting purposes on the roadside to the left of the roadway can be any colour selected by the road controlling authority, provided that such bollards are fitted with a *reflective white strip*, similar to that used on edge marker posts. The reflective strip should be located so it is clearly visible to night-time traffic approaching on that side of the road.

In order to maintain uniformity, road controlling authorities which wish to use plastic bollards in a colour other than white for non-sign supporting purposes, should adopt *one* colour for use throughout their area.

Although the *Manual of Traffic Signs and Markings* [7] states that the reverse side of RG 17 and RG 17.1 signs is to be black in colour, their use on bollards, where the reverse side cannot be seen, is very unlikely to compromise safety. Also, the *Traffic Regulations* [6] do not prescribe colours for the reverse side of these signs.

## 4.2.3 Layout and installation

A variety of layouts for the different bollard types are illustrated in Figures 2 and 3 in Appendix 2. These recommended layouts are for the guidance of road controlling authorities only and do not preclude the use of other layouts to suit different site requirements. The following points should be considered when designing the layout of plastic bollards for kerblines protection:

- to effectively protect the kerb, bollards should be located with a *maximum recommended clearance* of 300 millimetres between the kerb and the bollard
- bollards should be located so that they do not unnecessarily obstruct pedestrians or compromise the visibility of pedestrians
- bollards should be *highly visible* to approaching traffic
- typical bollard spacing ranges from 1 to 3 metres depending on the type of application and the site requirements. In New Zealand, 90% of cars and light vans have a maximum width greater than 1.40 metres [8].

Figure 4 in Appendix 2 illustrates how the plastic bollard can be installed. The base to which the bollard is attached can be bolted to a concrete pad, footpath or traffic island. The bollard sits over the base which can be either a plastic or timber block or a manufactured metal plate. The bollard is attached to the base by screws, preferably tamper resistant, mounted horizontally. Note that the dimensions of the bases for Type B and C bollards are the same.

## 5. Legal aspects

Unfortunately, neither the *Traffic Regulations* [6] nor the *Local Government Act* [9] adequately address the issue of liability in regard to accidental collision with roadside objects installed by road controlling authorities. However, the *Traffic Regulations* [6] do empower the Minister of Transport to instruct controlling authorities to remove or modify dangerous traffic islands or devices which, in his opinion, will or do create a hazard to road users. To date, the Minister has rarely needed to invoke this regulation because of the high standards to which controlling authorities have installed most traffic control devices.

Although the issue of liability in regard to accidental collision with concrete bollards, rocks and posts may be considered to be a matter of common law, it is clear that road controlling authorities have a social obligation to ensure that the road network they are providing is as safe as practicably possible for all road users. Therefore, in order to meet that obligation and minimise their exposure to liability it is recommended that road controlling authorities do not use unforgiving devices for kerblines protection, when safer more appropriate alternatives exist. It is likely that at some time in the future, the Land Transport Safety Authority will monitor compliance with this recommendation.

## 6. References

- [1] Jackett, M J. (December 1978) 'Ornamental rocks .... an environmental danger', *NZ Engineering Journal*.
- [2] American Association of State Highway and Transportation Officials (1977) *Guide for selecting, locating, and designing traffic barriers*
- [3] NAASRA (1987) *Safety barriers*
- [4] Transit NZ (1991) *Guidelines for planting for road safety*
- [5] Ministry of Transport (1993) RTS 6 *Guidelines for visibility at driveways*
- [6] Ministry of Transport (1976) *The Traffic Regulations*
- [7] Transit NZ/M.O.T (1993) *Manual of traffic signs and markings, 3rd edn.*
- [8] Ministry of Transport (1975) *Metric parking dimensions*
- [9] New Zealand Government (1974) *Local Government Act*
- [10] NAASRA (1988) Intersections at Grade Pt.5, *Local Area Traffic Management Pt. 10*
- [11] Traffic Authority of NSW (Undated) Guidelines for tree planting and maintenance on urban roads
- [12] Transportation Research Board, National Research Council (1991) Roadside safety features, Washington D.C Transportation Research Record No. 1302.

## 7. Acknowledgements

This document was compiled by the following working group, who gratefully acknowledge the assistance of the staff of Road and Traffic Standards district offices in Auckland, Wellington and Christchurch:

Murray Noone	Land Transport Safety Authority (convenor)
Brenda Wigmore	North Shore City Council
Vadi Vencatachellum	Auckland City Council
John Gottler	Manukau City Council
John Grummitt	Transit New Zealand, Hamilton Office
Steven Harte	Wellington City Council

## Appendix 1

Table 1

Acceptable method of kerbline protection	Situations for which method may be appropriate	Other considerations	Relevant section in guideline and other references
Road widening auxiliary turn lanes	<ul style="list-style-type: none"> <li>• Adjacent to intersection exceeding its capacity</li> <li>• High volume of turning traffic</li> </ul>	<ul style="list-style-type: none"> <li>• Appropriateness of existing intersection control</li> </ul>	4.1.1 Intersections at grade [9]
Plastic bollards	<ul style="list-style-type: none"> <li>• Cost considerations preclude road widening in the short-term</li> <li>• Protection and delineation required</li> <li>• Insufficient road reserve for widening</li> <li>• Replacing ornamental rocks or concrete bollards</li> <li>• To prevent parking on berm adjacent to roadway</li> <li>• Support required for RG 17 and RG 17.1 signs</li> </ul>	<ul style="list-style-type: none"> <li>• May be an interim method</li> <li>• Located so as not to impede pedestrian movement</li> <li>• Visibility to pedestrians, especially children, should not be compromised</li> </ul>	4.1.2 4.2.1 4.2.2 4.2.3
Safety barriers	<ul style="list-style-type: none"> <li>• History of loss of control accidents</li> <li>• Protection and guidance for pedestrians</li> <li>• Shielding errant vehicles from particular hazards</li> </ul>	<ul style="list-style-type: none"> <li>• Adequate clearance between hazard (or pedestrian) and barrier</li> </ul>	4.1.3 <i>Safety barriers</i> [3]
Planting and landscaping	<ul style="list-style-type: none"> <li>• Wide berm area between kerb and footpath</li> <li>• Requirement to beautify location</li> <li>• Requirement to minimise clutter of roadside objects</li> <li>• Change of streetscape environment</li> </ul>	<ul style="list-style-type: none"> <li>• All planting should be frangible</li> <li>• Landscaping design should minimise the risk of vehicle 'roll-over'</li> <li>• Sight distance requirements should not be compromised by landscaping or future growth of trees</li> </ul>	4.1.4 <i>Guidelines for planting for road safety</i> [4] RTS 6 [5]
Barrier kerbing (non-mountable kerbing)	<ul style="list-style-type: none"> <li>• Insufficient footpath width for other forms of kerbline protection</li> </ul>	<ul style="list-style-type: none"> <li>• Unlikely to deter heavy motor vehicles</li> <li>• Can create difficulties for pedestrians</li> </ul>	4.1.5

## Appendix 2

Figure 1: Recommended plastic bollards

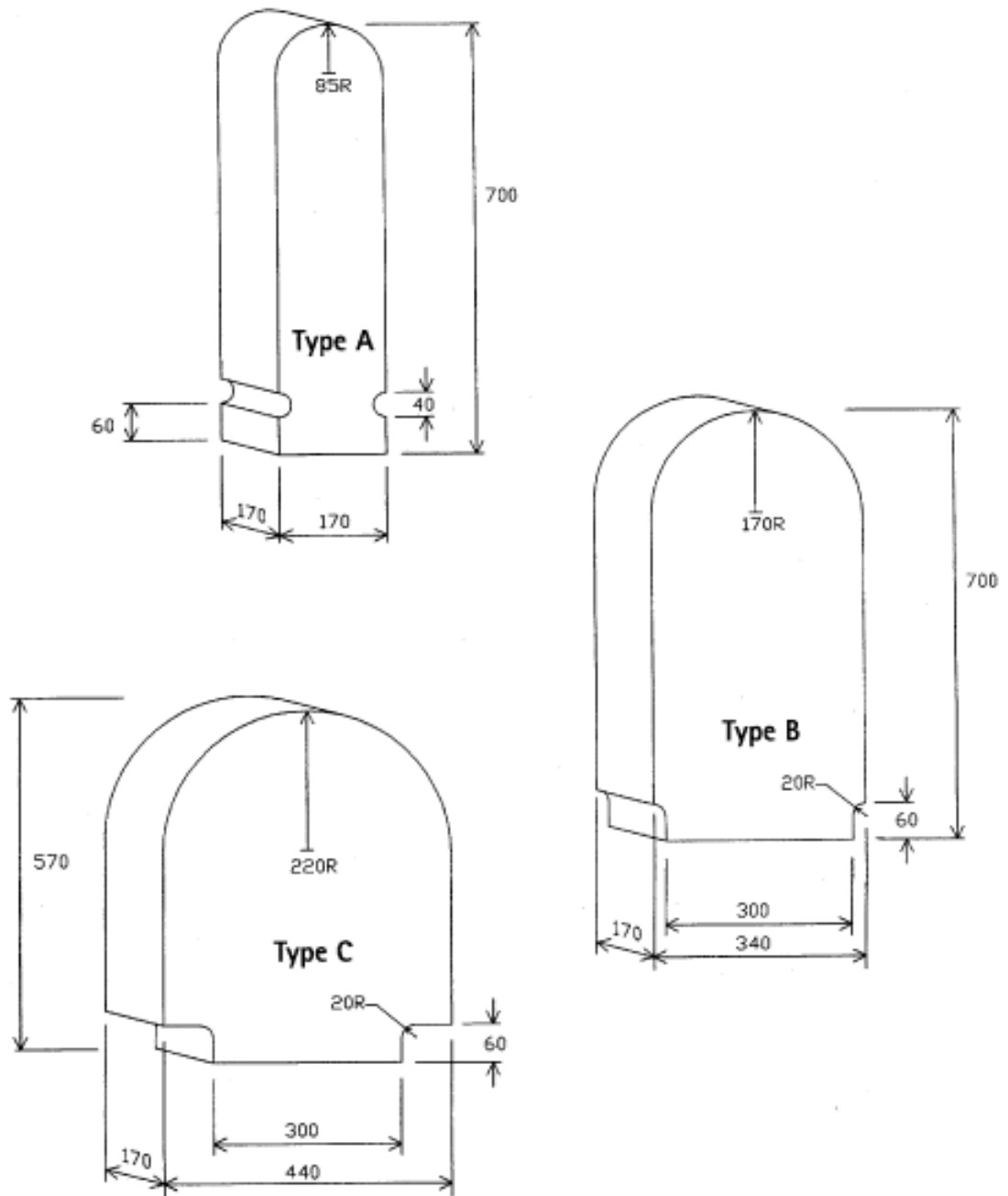

Figures 2 and 3: Typical bollard layouts

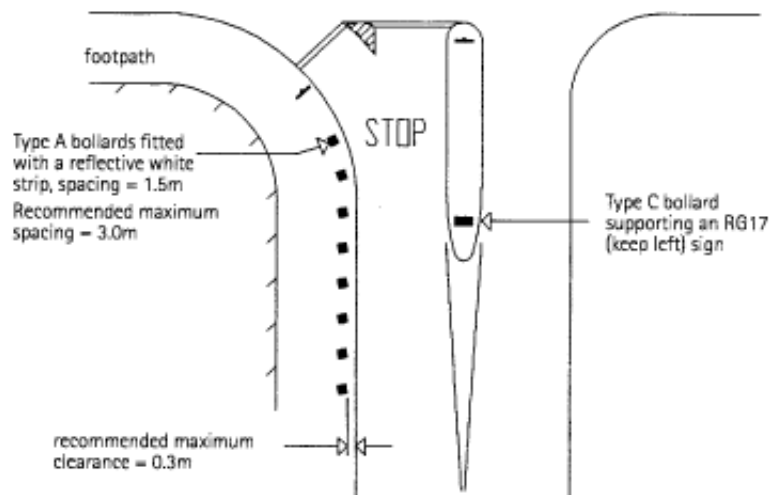
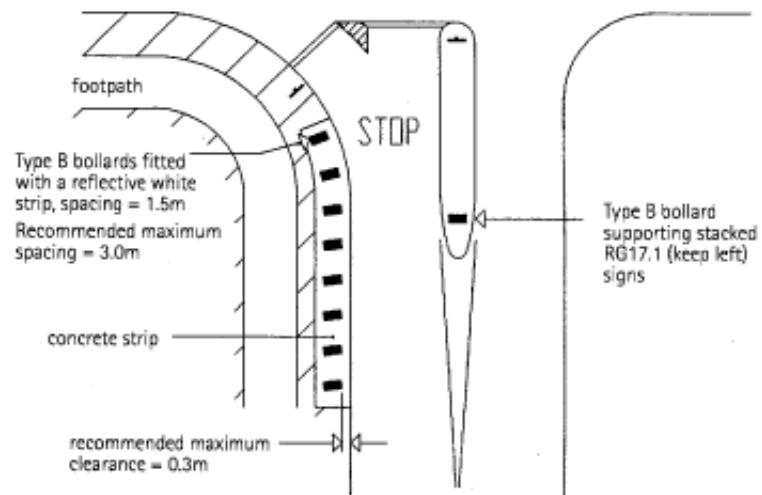
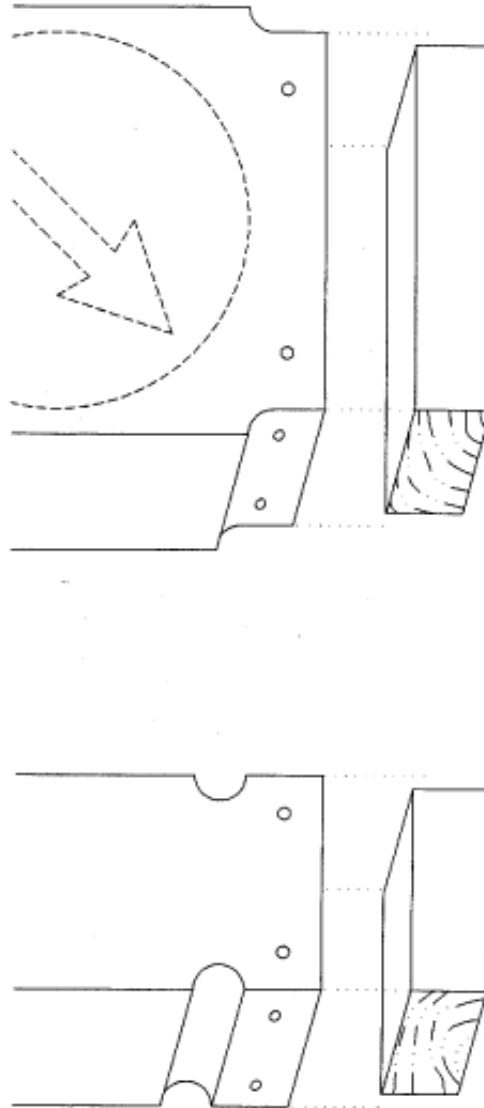

Figure 4: Bollard installation detail



## Road and Traffic Guideline publications

The following Road and Traffic Guidelines are available:

- RTS 1 Guidelines for the implementation of traffic control at crossroads (1990)
- RTS 2 Guidelines for street name signs (1990)
- RTS 3 Guidelines for establishing rural selling places (1992)
- RTS 4 Guidelines for flush medians (1991)
- RTS 5 Guidelines for rural road marking and delineation (1992)
- RTS 6 Guidelines for visibility at driveways (1993)
- RTS 7 Advertising signs and road safety: design and location guidelines (1993)
- RTS 8 Guidelines for safe kerblines protection (1993)
- RTS 9 Guidelines for the signing and layout of slip lanes (1994)
- RTS 11 Urban roadside barriers and alternative treatments (1995)
- RTS 13 Guidelines for service stations (1995)
- RTS 14 Guidelines for installing pedestrian facilities for people with visual impairment (1997)
- RTS 17 Guidelines for setting speed limits (1995)

The Guidelines may be purchased from:

Land Transport Safety Authority, Head Office (PO Box 2840, Wellington) or Regional Offices in:  
Auckland, (Private Bag 106 602), Wellington (PO Box 27 249) and Christchurch (PO Box 13 364).